

MER

EQUIPMENT

SAE Housings and Drive Plates Sizes

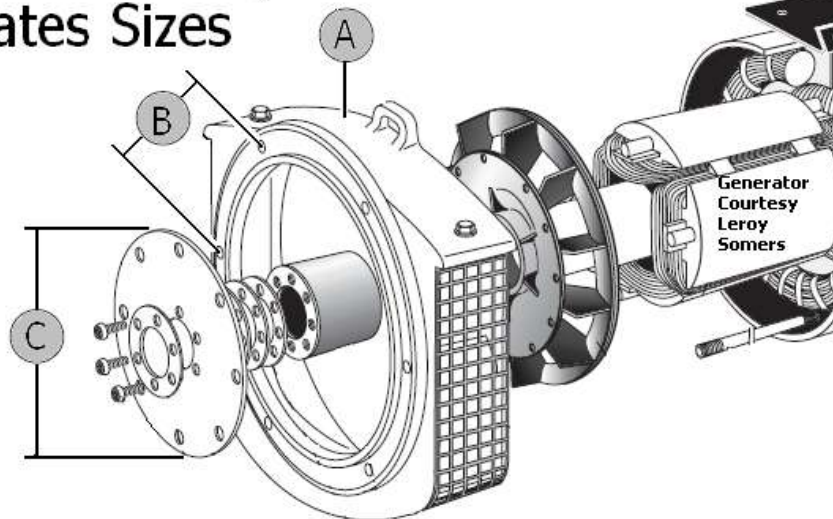

A-SAE Number Housing	B-Adjacent Holes Distance	C-OD. Drive Plates	
		Plate No.	Inches OD
SAE "0"	5.25 inches	No. 18 or, No. 14	22.50" O.D. 18.37" O.D.
SAE "1"	5.46 "	No. 14, 11.5	18.37" O.D.
SAE "2"	4.81 "	No. 11.5 or, No. 10	13.87" O.D. 12.37" O.D.
SAE "3"	4.42"	No. 8, 10 or, No. 11	13.87" O.D. 12.37" O.D.
SAE "4"	3.92"	No. 6.5, 7.5, 8, & 10	12.37" O.D. 10.37" O.D.
SAE "5"	5.15"	No. 6.5, 7.5, & 8	9.5" O.D.

Note: This drawing shows only the more common configurations and combinations.

SAE #	I. D.	BOLT CIRCLE	HOLES	USED WITH SAE CLUTCH
1	20.125"	20.8752"	12	14"
2	17.625"	18.375"	12	11.5"
3	16.125"	16.875"	12	11.5"
4	14.25"	15"	12	8"/10"
5	12.375"	13.125"	8	7.5"
6	10.5"	11.25"	8	6.5"

Commonly Used Flywheel and Housing Combinations

SAE	Bolt Center Diameter Bellhousing (XB)	Radius	Circumfrance Bolt C/L	# Bolts	Adjacent Bolt C/L distance	XG Dim. Inches
00	33.25	16.625	104.46	16	6.53	
0	26.75	13.375	84.04	16	5.25	
1/2	24.38	12.19	76.59	12	6.38	
1	20.88	10.44	65.60	12	5.47	
2	18.38	9.19	57.74	12	4.81	
3	16.88	8.44	53.03	12	4.42	
4	15	7.5	47.12	12	3.93	
5	13.12	6.56	41.22	8	5.15	
6	11.25	5.625	35.34	8	4.42	
SAE	Bolt Center Diameter Flywheel (XF)	Radius	Circumfrance Bolt C/L	# Bolts	Adjacent Bolt C/L distance	XG Dim. Inches
21	25.25	12.625	79.33	12	6.61	0
18	21.38	10.69	67.17	6	11.19	0.62
14	17.25	8.625	54.19	8	6.77	1
11.5	13.12	6.56	41.22	8	5.15	1.56
10	11.62	5.81	36.51	8	4.56	2.12
8	9.62	4.81	30.22	6	5.04	2.44
7.5	8.75	4.375	27.49	8	3.44	1.19
6.5	7.88	3.94	24.76	6	4.13	1.19
Delco 17.75	15.5	7.75	48.69	8	6.09	0.72
Delco 15.5	13.88	6.94	43.61	8	5.45	0.72
Delco 12.75	11	5.5	34.56	4	8.64	0

Detailed dimensions for coupling driven machinery to the engine.

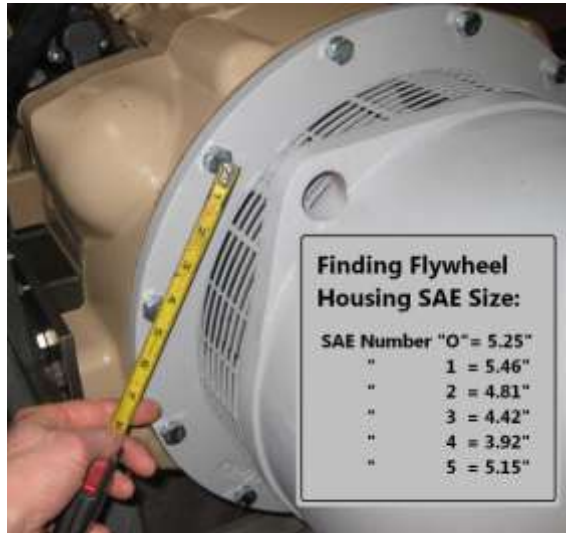

Simplified Housing Check