



We handle three main types of AC electrical power generators at MER that cover any fishing application. Our plan is to help you identify the machine on your boat and then get you lined up to go as far as checking the various parts of the system with a multimeter. Successfully working through these few easy checks and a cell phone call are all it takes to keep your fishing operation up and running.

Review: In *vol.6 (online)* we dissected the Anatomy of a Generator and compared power and efficiency in these 3 types:

**Synchronous Exciter-Regulated (SER) Generators**—very good at minimizing voltage fluctuations, often used on commercial fish boats for AC (Alternating Current) hotel power. SERs have a component that no MAC style generator has—an automatic voltage regulator (AVR). Just like new cars, you can order generators with a range of increasing voltage control with optional regulators.

**MAC Generators**—a transformer controlled machine that excels in applications where large electric motor-starting is a higher priority than weight or ultra-precise voltage control. Per unit of electrical power, these machines are heavier & more costly than more closely regulated sets. Commercial fish boats use MACs for motor starting such as in refrigeration systems, large electrohydraulics, and pump loads.

**Permanent Magnet-Excited Generators**—offer the best capabilities of both MACs and SERs, often used on vessels with large motor-starting loads and finicky electronics in the wheelhouse.

### Part 1: SER Generator Troubleshooting

For slightly low or high frequency just reset the engine speed until the cycles are at 60 Hertz for engines with electronic governors, 61.5 for mechanical governors.

Likewise, if slightly low voltage is the problem, locate the AVR (#1, *Figs. 1 & 2*)

and increase voltage as needed with the small voltage adjusting screw. The AVR controls voltage by increasing or decreasing the strength of the exciter's magnetic field.

When all is well the minimum voltage to the exciter windings (no load) is close to 6.7 volts, increasing to 21 volts under load. Regulators, though, are capable of a 63-volt maximum for starting heavy loads.

Brownouts and engine-speed variations can be a result of starting very high loads, & for this reason you may need to use the strategy of manually starting the largest loads first before adding the smaller

disconnected. Check continuity of both the sensing & control circuits for the AVR. Take notice how the unit smells—a burnt smell most likely indicates burned wiring or insulation.

Check the appearance of the voltage regulator (1, *Fig. 2*) followed by the regulator fuse (1a)—the only fuse most generators have. In older units the fuse is often inside the cabinet on top of the generator, newer units include the fuse on the AVR. Note that the fuse holder can also cause trouble if one of the internal contacts is burned or broken. Use your multimeter to verify continuity through the fuse and fuse holder.

### Beginning The Electrical Testing

This part of the procedure will show us one of three conditions: **Low voltage**, **No voltage**, or, finally, we'll test for the presence of **Residual voltage**. Note: Like a magnetized screwdriver tip, generators depend on their iron content to hold magnetism. A generator's residual magnetism creates *residual voltage* when the generator rotor spins, even if the regulator is not doing its part to increase the magnetism of the rotating member.

*Carefully!!* start the generator & check the voltage line-to-line (*Fig. 1*). In most fishing boats it's 208 V. Your system could be 240 or 480; you may want to verify.

If voltage is low, proceed to check AVR function. For a generator configured at 208 volts, if the actual generator voltage is only 50-60 volts line-to-line (L) or 25-30 volts line-to-neutral (N), you are seeing residual voltage. What this means is the voltage regulator, fuse, or wires to & from are faulty.

By checking voltage line-to-line & line-to-neutral, your voltages should be equal if the stator assembly and its individual coils (L1, L2, L3) are O.K. Therefore, replacing the AVR should set the system right.

However, if there is no voltage, it usually means severe damage, such as stator wires (4, *Fig. 2*) burned open. Check stator windings by disconnecting the 12 leads, 2 for each of the 6 coils around the barrel of the generator housing. *continued in box below ...*

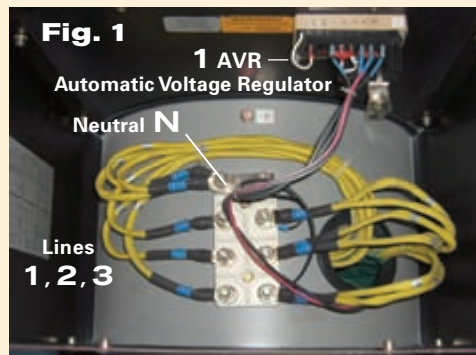

Typical AC-generator wiring connections.

loads. If, however, brownouts or engine-speed surges continue, it's time to suspect dirty air & dirty fuel filters or air in the fuel.

Track down air in the fuel by installing a transparent sight glass downstream of the engine's fuel transfer pump. After you get the engine fuel system bled of air and warmed up, put a load on the engine and watch for steady air bubbles in the sight glass. Just one bubble of air means there is 5% air in the fuel—5% is a substantial power loss and will cause brownouts and low power. Beginning with the engine, check and reseal every connection between the engine and the fuel supply.

### The Visual Check

Now do a visual check of the generator looking for burned wires or components. Run your fingers along the wiring, prodding & pulling gently to find anything loose or

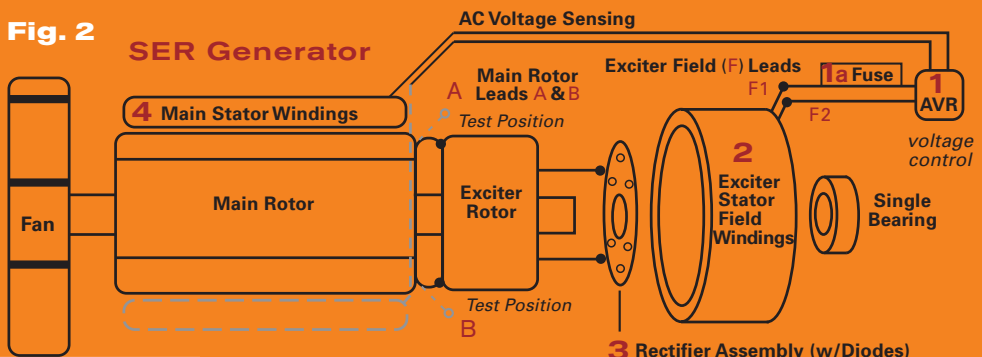

Lastly, to check the generator windings (Lines 1, 2, 3, & Neutral), check voltage between three legs first, then from each leg to neutral. Should be 120 V line-to-neutral.

If one leg has low voltage, suspect generator windings. If readings are equal, proceed to check the stator windings (2).

To get a quick idea of diode function (3) note that the generator may have full voltage with no load when a diode is faulty, but the voltage on the leg with the bad diode will not reach full rated voltage under

load. The diodes are located on or near the exciter rotor and the cluster of diodes make up the rectifier assembly (3).

### Important Safety Note

When beginning to check a generator, before starting it perform a voltage check of the generator leads (L1, L2, L3, & N, *Fig. 1*) to verify they are indeed electrically dead, and that the unit is safe to touch. This protects you from shore-power current or the possibility that another generator is running.

## Marine Engine & Repair

your premier provider of marine equipment, parts, and service—



since 1964

338 W. Nickerson St.  
Seattle, WA 98119 USA

In Seattle: 206.286.1817  
Toll Free: 1.800.777.0714  
Fax: 206.286.1917  
Cell: 206.280.1090

[www.merequipment.com](http://www.merequipment.com)



Sylvia Ettefagh and her husband, John Verhey, are two of MER's favorite customers. We met at Fish Expo about 12 years ago. Sylvia was one of the few women at Fish Expo and one you don't forget. Who-ever coined the phrase "Alaska, where men are men and women are too". They were talking about Sylvia. The first thing you encounter is that smile, warmth, and confidence as big as Alaska.

They wanted full time electricity and back up power off grid, but didn't want to run a generator all the time. Sylvia had done a lot of research, knew exactly what she wanted, just needed a little help with components and design.

Mike and Bob had recently been kicking around designs for a fully automatic system with inverter, charger, controller, and "smart" diesel generator that would turn on and off only when it needed to charge the battery bank. Along came Sylvia and John at just the right moment.

Sylvia says they talked with Trace (the inverter people), with Bob and Mike—and with others as well—but that "Bob and Mike were most interested in working with us on the project."

"Mike and Bob at MER actually initiated and took the reins," she says. "They talked to Trace to get the automatic system set up right—we could go back to work—and not worry about all the details."

**"Our neighbors, running generators full time were burning 300 gallons a month."**

**With our Inverter & 9Kw MER generator setup? "We burned 30."**

Now since the power grid came to them, they use the MER generator as a backup system: "Of course now we've expanded," says Sylvia. "We have freezers full of spot tail prawns. When city power goes out, the auto-transfer switch kicks in seamlessly—first to the inverter then the generator, "Our computers don't even blink," she says. "Don't need a big battery bank, everything works, haven't had any problems with it."

"Had a starting issue once", she says. "Talked to Mike on the phone—loose wire on a relay—easy fix. "Not bad for 10 plus years of service."

"When it came time to repower our gillnetter," she continues. "John Deere was one we were interested in. Started talking about a repower years ago with MER, seems we always talked John Deere with them."

After considering other engine options Sylvia says it came down to a Deere or a Cat.

**"John Deere won out because it was a more popular engine in Southeast and because we wanted to work with**

**MER. It's the parts and service thing."**

She says they also checked with their friend Bob Dolan on the Jaleo—He bought a Deere from MER back in '03, and "between our experience with MER and Bob Dolan's recommendation, we returned to MER to buy our engine and the generator to run our new RSW system."

**Fidelia swapped her 3208 CAT-V8 for a John Deere 6.8 Liter electronic engine.** Bob says "we considered the 8.1L engine and the 6.8L. In the end the 201hp option made

more sense. Didn't want the extra size, or weight. The boat could have gotten a little more speed, but would have needed a different prop and transmission."

"Everyone would rather go faster—but do you really need speed at these fuel prices?"

In the end "It was fuel," Sylvia says, "and also two factors: No. 1, we bought the generator at home from Bob and Mike before, and we've been really glad to work with them and happy with the generator. No. 2, wanted to choose an engine more common in the fleet. When you're out there—if something goes wrong—you can talk to somebody, get spare parts."

With the spring '07 JD install, John and Sylvia also added MER's 12-kW motor start generator to run freezers, and the 7-1/2-ton RSW system.

John was able to do most of the main engine installation himself. Same with the generator—if a problem, he'd call down and talk to Mike.

"We expanded the engine room, took the Cat out, and cleaned up the bilge. To get an idea how things were going to fit Bob suggested putting a measuring tape in there, take digital pictures, e-mail to MER and they made modifications."



John Verhey and their JD 6068, rated M-3 @ 201 hp

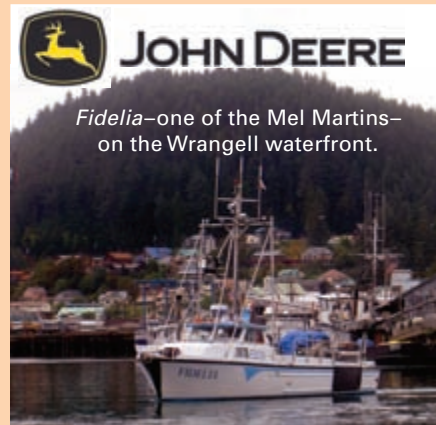

Fidelia—one of the Mel Martins—on the Wrangell waterfront.

PHOTOS COURTESY SYLVIA FISHING CO.

# SHOOTING TROUBLE

## Erosion Corrosion—PITS & CAVITATION

Welcome to Pits & Cavitation—the turbulent, high-velocity corrosion, & 3rd in our series on various ways metals corrode & how best to protect your boat. Following vol. 8's Galvanic Action & Electrolysis (from dissimilar metals in seawater) and vol. 9's Rust & Scaly Buildup (crystallized seawater salt deposits), Erosion Corrosion is borne of high-velocity flows.

Strong currents flow through machinery in your boat pumps and engine. Water running at high speed through piping, across impellers, and through exchangers and coolers can easily erode and seriously corrode those metal parts. Short of catastrophic failure you're still looking at capacity loss and efficiency drops.

**Erosion corrosion** (impingement attack) takes place under flowing conditions and is not the result of mechanical erosion of the metal itself, but of eroding the film of corrosion products ordinarily protecting metal at lower velocities. The flow generates a shear stress that damages the protective layer on the material. And once bare metal's exposed to high-velocity liquids it corrodes rapidly—corrosion increasing with velocity and varying with the smooth-

ness of the metal surface, degree of turbulence, and presence of impurities (like sand).

**Pitting** corrosion is a localized form of attack resulting from breakdown of the thin protective film on a metal. You don't need two different metals to get pitting. One metal, subjected to water motion or vibration, can pit, the rapid movement of liquid over metal causing erosion corrosion. Very slight motion, such as vibrating of the metal surfaces themselves, can lead to surface pitting. Usually metal particles also form, rust and scale filling pits as a powdery camouflage concealing what lies beneath—the corroded and weakened metal.

**Cavitation** corrosion is a particular form of erosion caused by the implosion of gas bubbles (cavities) on a metal surface. It occurs in areas with high flow rates and rapid pressure changes, causing gas bubbles to collapse. As these tiny cavities collapse a tremendous pressure develops in a sort of hammering action—hammering your metals. Most often seen on a propeller blade peppered with tiny "drill" holes or telltale scouring, pitting and cavitation occur unseen in your engine as well.

John Deere & Yanmar recommend

specialized coolants that coat the metal surfaces to minimize these problems. If the system's incorrectly designed, failure is inevitable; for instance, if a transmission oil-cooler's undersized, water goes through at high velocity and erodes. Or if the wrong-size keel cooler on a keel-cooled engine creates too much restriction, water can't flow up to the impeller—creates a vacuum—air bubbles—cavitation eats the water pump. No coolant or additive can prevent damage from a poor design.

**Sacrificial additives are key:** SCAs, Supplemental Cooling Additives (vols. 4, 5, & 9 online—really check them out! Good info, tight spaces, can't repeat every time).

Antifreeze Additives in a Nutshell: to work they must deplete. Test often (the strips); replace, replenish as needed.

Here at MER we make sure the diameter & core of your cooling-system pipes are of sufficient size to prevent erosion. We sell only cupronickel oil coolers for better stability in seawater than the less expensive copper. **Pay now or pay later—because most engine failures begin in the cooling system!**

Next up: You're Grounded! AC, DC Bonding Systems  
Again, many thanks to Jerry Kirschenbaum's definitive Electrolysis & Corrosion series, Wooden Boat, 1978.



When cutting the hold out to put the engine in, John expanded for the new RSW at the same time.

"These 38' boats," Sylvia says, "we're trying to run them like a 58-footer. Took out two of our side fish holds, expanded the port side for the RSW, starboard for the Isuzu—and maintained stability. Got a new, keel cooler hooked up for the genset. Exhaust was all new, ended up with the same prop."

"MER rebuilt our 506 Twin Disc (2.5:1) gear and installed it on the engine. They'd already run it, tested the reduction gear, we were able to slide it right in—everything fit."

"I know that we're burning less fuel—now 30% less fuel on an opening—getting more speed out of the boat. Top speed I could get out of the Cat was 8-1/2 kts light.

"We run the Deere at 2000 rpm and burn 5.1 to 5.3 gal/hr, making 8-1/2 kts. We top out at 9.7 kts empty, @ 2600 rpm, but we're using twice the fuel for that extra knot."

On the Seattle-to-Wrangell run the Cat used 480 gal., had to refuel in Prince Rupert, B.C., to get to Ketchikan, but Sylvia says they predict the Deere makes Ketchikan non-stop on only 375 gal.

And the noise? "It is quiet." Electronics? "It's great," she says, "it's great. You have a good feel for exactly what you're doing so you can dial in how you want to run your engine. The thing in SE is the big tides. With the current you gotta think how you're running with or against. So it's hard to figure speed with the tide."

"With the electronic engine and GPS you can really dial it in, and these days it matters."

"Getting ready to halibut fish the engine wouldn't start," Sylvia recalls. "Readout gave fault code, looked it up, said throttle control relay—looked down, sure enough. Saved calling a mechanic or looking around for hours figuring it out."

"I'll tell ya this," she adds: "The MER is more expensive no doubt about it. But—it's always about stepping back and looking at the big picture, not what you spend here or there. It's how much you spend overall and I think it takes less money to buy things from MER," says Sylvia. "Everything was done right, came out of the crate, ready to go. All the parts were there."

"Bob makes things square up front. Mike has the answers—or works through the answer—real well."

With a Deere and a coupla' MER Gensets in their fleet, we'll be friends, working together for many years to come.

Take photos of your engine room with a tape measure ...

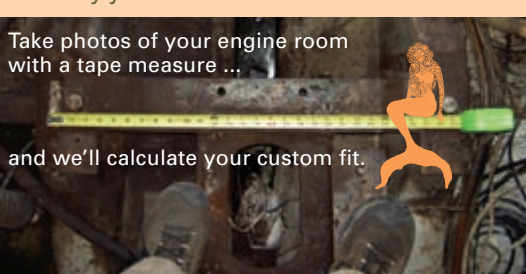

and we'll calculate your custom fit.

lots of fishermen have interesting stories to tell, but they don't have this one.

Meet Sylvia Etefagh—Wrangell gillnetter, longtime NMFS fisheries observer, lived off the grid, born and raised in Iran to an American mother and Iranian physician father.

I mean, c'mon; how many of us are fluent in Farsi. Truly fluent.

Moving stateside with her family in 1975 ahead of the ayatollah revolution, Sylvia later lost her father in the melee when he stayed behind.

With a newly minted marine biology degree from Texas A&M in 1981, Sylvia says she couldn't

find a job in her field back in those early Reagan years (fisheries? what fisheries?) and considered a return to school in engineering when she got the call from NMFS.

"I've been fishing since 1987," says Sylvia, "but I've been in fisheries, starting with NMFS as an observer, since 1983." On the big boats in big water in rough country—Kodiak, Dutch—first on Japanese factory ships "keeping them honest," she says. Only woman on the boat and big chunks of months at a stretch, she worked at learning the language, says "coming from an Eastern culture made it easier." Sylvia then switched teams to Joint Ventures as an American coordinator for the private sector, repping American boats delivering fish to those Japanese factory ships. Remember back when Eastern Cut came to Alaska black cod? Sylvia was there, going aboard American factory trawlers for the Japanese teaching us gringos how to process for the Japanese market—rockfish, fillets, Pollock roe.

"I'm kind of the Roe Queen of the Bering Sea," she says with a laugh.

It was here she found the threads to

her future: fellow observers Rikki Ott telling Copper River gillnet stories, and John Verhey she later married in '92. Along the way to here, however, Sylvia bounced



Etefaghs: Sylvia & nephew Keivan

around several Southeast towns on several boats in a coupla' fisheries—crewing seiners or gillnetters when she could, scraping and painting when she couldn't, working the Bering Sea in

between—and always with her eye on the prize: her own gillnet operation.

*Fidelia*—Spanish for Faithful—came in 1989 after Sylvia called John up and said, "Alright, I want to be a gillnetter," and he replied, "O.K., so we'll buy a gillnetter." Fast-forward 2007—their stern picker fishes all species of salmon, changes over to fish Sylvia's halibut IFQs and then over to shrimp pots, freezing spot-prawn tails onboard and direct-marketing the catch since 1992 as The Sylver Fishing Co.

"We fish together, we trade off," she says. "I still work in Dutch Harbor managing one of the American Fisheries Co-ops, since 2000—January, February, March up there, back and forth."

This spring Sylvia and John repowered with a John Deere, adding a MERmade Isuzu genset to run the new refrigeration.

Oh, and did we mention Sylvia's in treatment this year for breast cancer. No, not too many in the fleet can say they've had to tackle that one.

*Fidelia's* Sylvia: She's tough, she's joyful, she's one of a kind—and we're glad she chose to work with us. More power to Sylvia.

## Killer High-Pressure Fuel Systems



Just about all the HPCR (High-Pressure Common Rail) systems regardless of maker are running wide-open throttle pressures above 20,000 psi—and bringing serious life-threatening issues with it. People have died from being injected with diesel fuel while checking for fuel leaks. A pinhole leak at 20,000 psi could chop off your hand before you even knew you did it. If you suspect a fuel leak, don't use your hand to locate it—or you may find yourself pulling back a stump. Use a piece of cardboard or paper to look for a suspected leak. Even at idle, fuel pressure is 5,000-6,000 psi, high enough to puncture skin and deliver a lethal injection of diesel fuel. Use good common sense and read the manuals about the proper way to bleed and maintain the fuel system.

A piston pump building fuel pressure above 20,000 psi has exceptionally close tolerances on moving parts. Surfaces on pistons and barrels are like mirrors, affected by fuel quality far more rapidly than ever before. Filtering of water, dirt, rust, and scale is critical. Even some additives are strictly prohibited—their large molecular structures can ruin your fuel pump (reread Fuel Lubricity, vol. 4, online).

Most engines come with dual fuel filters, usually a 10- or 15-micron (µm) primary with a 2-µm secondary. A 2-µm filter removes particles 100 times smaller than the diameter of a human hair. Common sense dictates a 30- to 50-µm pre-filter/water-separator between fuel tanks and engine, but pre-filters can restrict fuel delivery enough to set off the low-pressure alarms. Might need a booster pump near the tanks to prime the system and push fuel through the pre-filter.

The ECU (Electronic Control Unit) monitors low-pressure fuel delivery—included in most diesel alarm systems because, if starved for fuel, that sophisticated high-pressure fuel pump loses all lubrication for the plungers. Run it dry for a second and it's toast. Pass a little water into that nice mirror surface and it will probably go right on through the system. Trouble starts when turning the engine off and water sits on those perfectly honed surfaces—where they'll pit and corrode—til next time you run the engine when they're no longer able to produce the required fuel pressure. Then you're looking at some very expensive pump repairs.

Read the manuals, ask questions, get to know your engine and its fuel and electrical systems. Brave New World—not all the old rules apply.

*The MERmade Mechanic*

Come visit us at  
**PACIFIC MARINE EXPO**  
Booth #1321

JOHN DEERE  
6068TFM

Sylvia's Fidelia

*News You Can Use!*

vol. 10 Fall 2007

*The MERmade Mechanic***MARINE ENGINES & REPAIR COMPANY, INC.**

**Erosion Corrosion ♦ Killer Pressure  
♦ SER-Generator Troubleshooting ♦  
Sylvia's MERmades ... & Ivan Fox**

*From the Founder***IVAN FOX REMEMBERS ... THE LOGGER, PART 2**

*Part 1: Saving the San Juan Fishing & Packing Co. 105'-power scow—loaded, grounded, towed deep, sinking, & turned turtle ...*  
We now had a cable attached to the *Logger*, which was upside down, with the bow about 8 ft. in the air. After a discussion with the *Robert M.'s* captain, Chuck Turner, we decided to slowly tow the vessel to a site on a small island across the bay from Port Bailey. After a couple hours of towing we arrived at the designated place for stranding and got the *Logger* as far as we could up the beach. When the tide had gone out the bottom of the *Logger* was pretty well exposed.

What a mess. The mast was broken off and still attached with the cable rigging. The bow had a hole in it, approximately 8'x10'. Boyd Roberts, our foreman from Uganik, decided to patch the hole in the bow while it was upside down. We picked up about a dozen sheets of 3/4" plywood, exterior grade, and 15 gal. of tar roof coating. It took a couple days to patch the hole. By this time we had a couple of divers on the job. They reported that most of the salmon had come out of the tank during the tow. Our problem now was how do we upright the vessel as it was on the beach upside down. During high water we towed the vessel off the beach into deep water and rigged lines around the hull and towed on them trying to roll it over. We worked on this for several days, then decided to send the *Viekoda* back to Uganik to pick up a portable air compressor. We had one of the divers take the air hose down and put it in the center tank and started up the compressor. After a couple hours the bow started to rise as the air in the tank was forcing the water out. After about 2 more hours the bow had risen until it was 30-40 ft. in the air, and to our utter amazement the *Logger* slowly rolled upright with the bow in the air. We had changed the center of gravity by forcing the water out of the tank.

We quickly towed the *Logger* back to the beach. After the tide went out we tried pumping the water out of the hold but had problems with our pump plugging up with junk and debris. We finally lost to the tide coming back in and decided that pumping wasn't going to work. We borrowed a 1 1/2" hand auger from Port Bailey. When the tide went out again we walked under the *Logger* and drilled a hole in the shaft alleys just aft of the engines. This worked. After a few hours we had the vessel drained, we went down into the engine room & drove wooden plugs into the holes. When the tide came back in the *Logger* was floating like a duck. We towed her to Uganik where we poured concrete from the inside over the plywood patch, dried out the living quarters, installed a radio & had the galley stove working. We had 2 people move aboard and towed the vessel to Seattle with the tender *Deep Sea*. Maritime Shipyard made the repairs.

